

## Nyloc Insert Nut

**Thread Type:** BSW - Coarse

**Thread Direction:** Right Hand

**Material:** Carbon Steel

**Class Grade:** Low Tensile Grade 2

**Finish:** Zinc Plated

**Corrosion Protection Level:** Moderate

**Standard:** IFI-100NE

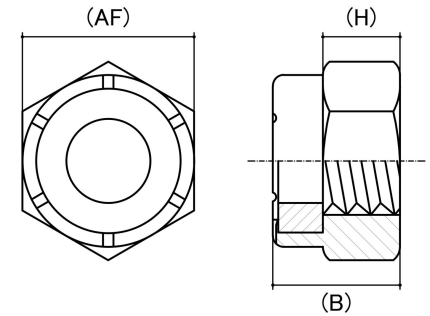

*CAD drawings shown for graphic representation only.\**

Size	Thread Pitch (TPI)	Thread Type	Overall Nut Height (B) (mm)		Hex Height (H) (mm)	Across Flats (AF) (mm)		Spanner Size (AF) (inches)	sku (qfind)
			Min	Max	Nom	Min	Max		
1/2"	12	Coarse	16.00	16.70	13.54	20.32	20.83	7/8	41NW12

**Disclaimer:**

Dimensional data and technical information was obtained from publicly available sources and not acquired through standard agencies. It has been completed and compiled for reference purposes only; where discrepancies are found they are subject to change without notice. Bolt & Nut Australia makes no warranties or representations regarding the accuracy and validity of the compiled information and data. Contact the relevant standard authorities for accurate and detailed information.

\* CAD drawings may not reflect diameter, thread length or overall length.

© Bolt & Nut Australia Pty Ltd. All rights reserved.

Version: 18 Mar 2024